

ROTACOD

Absolute single turn encoders

Series

HS58 • HS58S • HSC58



- Compact single turn encoders for feedback applications
- High resolution up to 262144 cpr
- Additional incremental track, 2048 PPR sin/cos
- Precise and fast optical sensing



HS58 • HS58S • HSC58

ENVIRONMENTAL SPECIFICATIONS

Shock:	100 g, 6 ms
Vibrations:	10 g, 5-2000 Hz
Protection:	IP67, IP65 shaft side
Operating temperature range:	-25°C +85°C (-13°F +185°F)
Storage temperature range:	-40°C +100°C (-40°F +212°F) (98% R.H. without condensation)

MECHANICAL SPECIFICATIONS

Dimensions:	see drawing
Shaft diameter:	Ø 6, 8, 9.52, 10, 12 mm
Hollow shaft diameter:	Ø 14, 15 mm
Reducing sleeves BR1-xx from Ø 15 mm to:	Ø 6, 8, 9.52, 10, 11, 12
Shaft loading (axial, radial):	40 N max.
Shaft rotational speed:	12000 rpm, 9000 rpm continuous operation
Starting torque (at 20°C):	HS58: 0,15 Ncm (typ.) HS58S, HSCxx: 0,4 Ncm (typ.)
Bearings life:	400 x10 ⁶ rev. min. (10 ⁹ rev. min. with 20 N shaft loading max.)
Electrical connections:	M12, M23 plug or cable output 2 m (6.56 ft)
Weight:	~ 300 g (10,6 oz)
Option:	• additional cable

ELECTRICAL SPECIFICATIONS

Resolution:	SSI, BiSS: 18 bit max. sin/cos: 2048 PPR AB, /AB: 2048, 4096, 8192
Accuracy:	± 0,007°
Output circuits:	SSI, SSI + 1Vpp, SSI + Line Driver 5V, BiSS (B-mode, C-mode) + 1Vpp
Output code:	Gray, Binary
Counting frequency:	220 kHz max.
Power supply:	+10V +30V
Power consumption:	0,9 W
Protection:	against inversion of polarity, short-circuit
EMC:	electro-magnetic immunity, according to: EN-61000-4-2 EN-61000-4-4
Optoelectronic life:	100.000 h min.
Functions:	• Counting direction (input) • Zero setting/Preset (input)

MATERIALS

Flange:	anticorrosive, UNI EN AW-6082
Housing:	anticorrosive, UNI EN AW-6082
Bearings:	ABEC 5
Shaft:	stainless steel, non magnetic, UNI EN 4305
Light source:	GaAl diodes

ACCESSORIES

EPFL121H:	M23 12 pin connector
EM12F8:	M12 8 pin mating connector
EM12F12:	M12 12 pin mating connector
PAN/PGF:	flexible couplings
BR1:	reducing sleeves
EC-CR12F-S28-T12-xx:	cordset xx m, M23 connector
EC-M12F8-LK-M8-xx:	cordset xx m, M12 8 pin connector
EC-M12F12-LK-T12-xx:	cordset xx m, M12 12 pin conn.
LKM-386:	fixing clamps

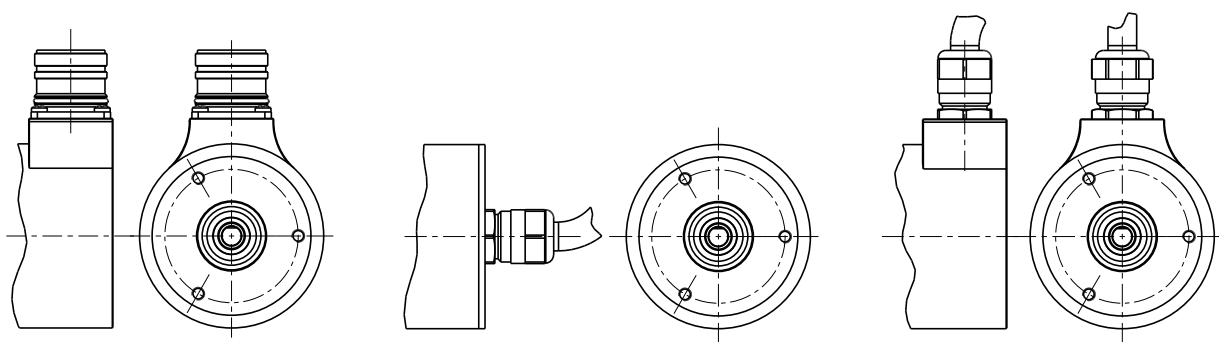
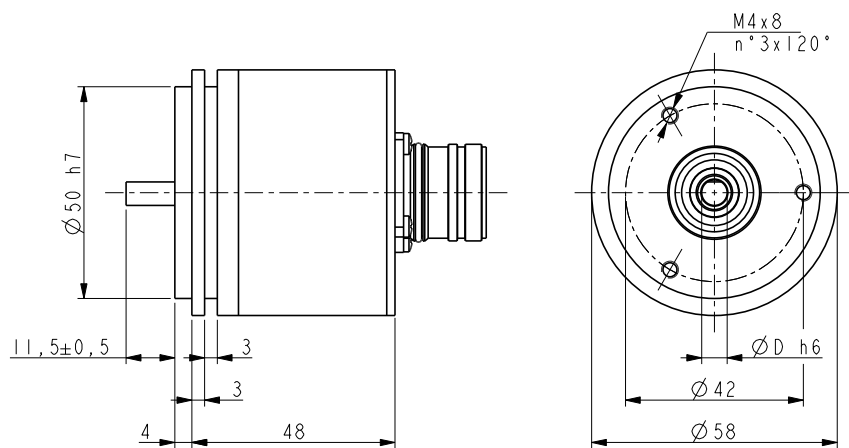

HS58

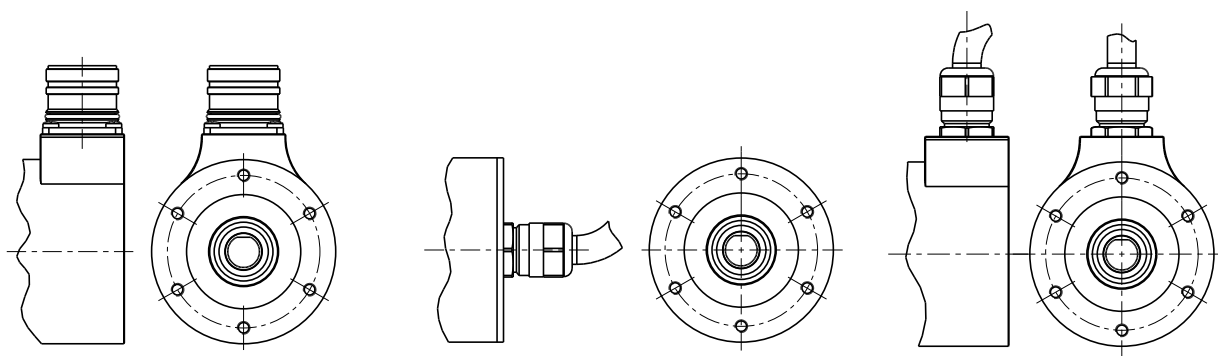
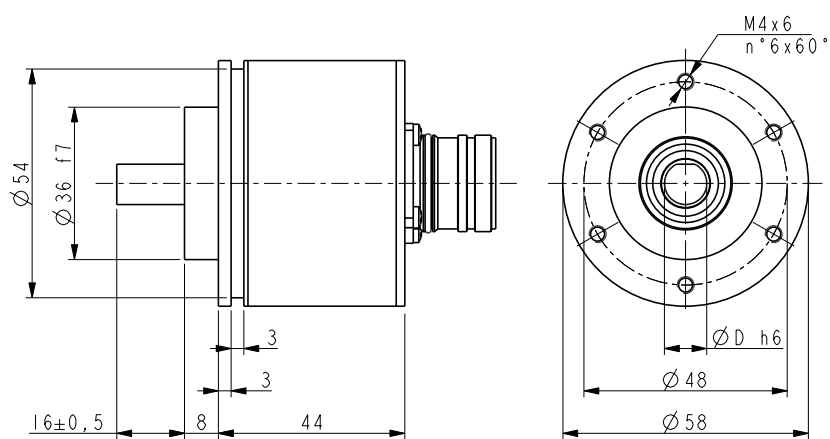

HS58S

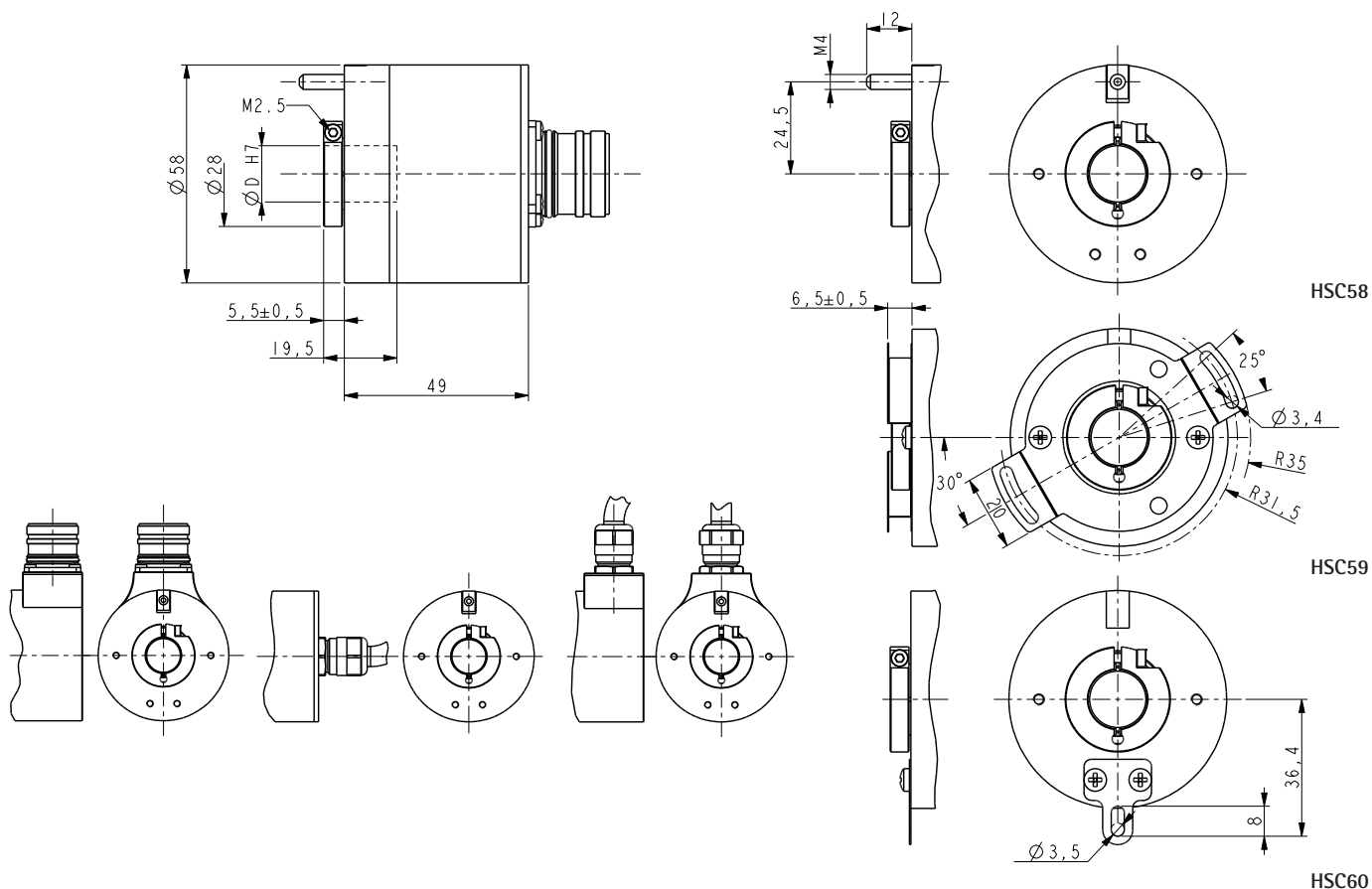

Order code

HS58	XX	/	XX	-	XX	-	X	XX	/Sxxx
HS58S	Ⓐ		Ⓑ		Ⓒ		Ⓓ	Ⓔ	Ⓕ
HSC58									
HSC59									
HSC60									

Ⓐ RESOLUTION

13 = 8192 cpr
16 = 65536 cpr
18 = 262144 cpr

Ⓑ OUTPUT CIRCUITS

GV = SSI, LSB aligned, Gray code + 2048 PPR sin/cos
BV = SSI, LSB aligned, Binary code + 2048 PPR sin/cos
GA = SSI, LSB aligned, Gray code
BA = SSI, LSB aligned, Binary code
I7 = BiSS C-mode + 2048 PPR sin/cos
I8 = BiSS B-mode + 2048 PPR sin/cos
G1 = SSI, Gray code + 2048 PPR AB, /AB
G2 = SSI, Gray code + 4096 PPR AB, /AB
G3 = SSI, Gray code + 8192 PPR AB, /AB
B1 = SSI, Binary code + 2048 PPR AB, /AB
B2 = SSI, Binary code + 4096 PPR AB, /AB
B3 = SSI, Binary code + 8192 PPR AB, /AB

Ⓒ SHAFT DIAMETER

6 = 10 mm
8 = 8 mm
P9 = 9.52 mm, 3/8"
10 = 10 mm
12 = 12 mm
14 = 14 mm (HSCxx)
15 = 15 mm (HSCxx)

Ⓓ CONNECTION POSITION

- = axial
R = radial

Ⓔ CONNECTIONS

L2 = cable output 2 m
L5 = cable output 5 m
L10 = cable output 10 m
M2 = M23 12 pin plug
M = M12 8 pin plug
M1 = M12 12 pin plug
(only for GV, BV, GA, BA)
(except with GV, BV, GA, BA)

Ⓕ CUSTOM VERSION